

Castor Wheels



Castor Wheels Series ALPHA

housing made of pressed steel, zinc-chromatised,
wheel centre made of pressed steel
Tread: solid rubber, black, roller bearing



BETTER MOBILITY. BETTER LIFE.

Plate Fitting

Bolt Hole



Swivel Type

Fixed Type

Brake Type



double ball bearing swivel head,
dustguard, wheel axle with nut

fork made of pressed steel,
zinc-chromatised, wheel axle
with nut

with total lock, tail end of castor,
double ball bearing swivel head,
dustguard, wheel axle with nut

Art. No. swivel type	Art. No. fixed type	Art. No. brake type	size (mm)	load capacity (kg)
3470 DVR 100 P62	3478 DVR 100 P62	3477 DVR 100 P62	100	75
3470 DVR 125 P62	3478 DVR 125 P62	3477 DVR 125 P62	125	100
3470 DVR 160 P63	3478 DVR 160 P63	3477 DVR 160 P63	160	135
3470 DVR 200 P63	3478 DVR 200 P63	3477 DVR 200 P63	200	205



BETTER MOBILITY. BETTER LIFE.

Castor Wheels



Castor Wheels Series ALPHA

housing made of pressed steel, zinc-chromatised,
wheel centre made of polypropylene
Tread: solid rubber, black, roller bearing



BETTER MOBILITY. BETTER LIFE.

Swivel Type



double ball bearing swivel head,
dustguard, wheel axle with nut

Fixed Type



fork made of pressed steel,
zinc-chromatised, wheel axle
with nut

Brake Type



with total lock, tail end of castor,
double ball bearing swivel head,
dustguard, wheel axle with nut

Art. No. swivel type	Art. No. fixed type	Art. No. brake type	size (mm)	load capacity (kg)
3470 PVR 080 P62	3478 PVR 080 P62	3477 PVR 080 P62	80	70
3470 PVR 100 P62	3478 PVR 100 P62	3477 PVR 100 P62	100	75
3470 PVR 125 P62	3478 PVR 125 P62	3477 PVR 125 P62	125	100
3470 PVR 160 P63	3478 PVR 160 P63	3477 PVR 160 P63	160	135
3470 PVR 200 P63	3478 PVR 200 P63	3477 PVR 200 P63	200	205

Stainless Steel Castor Wheels Series ALPHA

housing made of stainless steel, wheel centre made of polyamide, white
Tread: polyurethane, purple, roller bearing, stainless

Swivel Type



double ball bearing swivel head,
dustguard, wheel axle with nut

Fixed Type



fork made of stainless steel,
wheel axle with nut

Brake Type



with total lock, tail end of castor,
double ball bearing swivel head,
dustguard, wheel axle with nut

Art. No. swivel type	Art. No. fixed type	Art. No. brake type	size (mm)	load capacity (kg)
8470 UAD 080 P62	8478 UAD 080 P62	8477 UAD 080 P62	80	100
8470 UAD 100 P62	8478 UAD 100 P62	8477 UAD 100 P62	100	150
8470 UAD 125 P62	8478 UAD 125 P62	8477 UAD 125 P62	125	200
8470 UAD 160 P63	8478 UAD 160 P63	8477 UAD 160 P63	160	350
8470 UAD 200 P63	8478 UAD 200 P63	8477 UAD 200 P63	200	400

Castor Wheels



Castor Wheels Series ALPHA

housing made of pressed steel, zinc-chromatised,
 wheel centre made of polyamide, black / white, roller bearing
 all types optionally available in white colour!
 size 200 mm only available in white colour!



BETTER MOBILITY. BETTER LIFE.

* to order white version please add „white“ to the Art. No.

Plate Fitting

Bolt Hole



Swivel Type



double ball bearing swivel head,
 dustguard, wheel axle with nut

Fixed Type



fork made of pressed steel,
 zinc-chromatised, wheel axle
 with nut

Brake Type



with total lock, tail end of castor,
 double ball bearing swivel head,
 dustguard, wheel axle with nut

Art. No. swivel type	Art. No. fixed type	Art. No. brake type	size (mm)	load capacity (kg)
3470 UOR 100 P62	3478 UOR 100 P62	3477 UOR 100 P62	100	200
3470 UOR 125 P63	3478 UOR 125 P63	3477 UOR 125 P63	125	250
3470 UOR 160 P63	3478 UOR 160 P63	3477 UOR 160 P63	160	350
3470 UOR 200 P63	3478 UOR 200 P63	3477 UOR 200 P63	200	350



BETTER MOBILITY. BETTER LIFE.

Castor Wheels

Castor Wheels Series ALPHA

housing made of pressed steel, zinc-chromatised,
wheel centre made of polypropylene, dark grey,
roller bearing



BETTER MOBILITY. BETTER LIFE.

Swivel Type



double ball bearing swivel head,
dustguard, wheel axle with nut

Fixed Type



fork made of pressed steel,
zinc-chromatised, wheel axle
with nut

Brake Type



with total lock, tail end of castor,
double ball bearing swivel head,
dustguard, wheel axle with nut

Art. No. swivel type	Art. No. fixed type	Art. No. brake type	size (mm)	load capacity (kg)
3470 POR 080 P62	3478 POR 080 P62	3477 POR 080 P62	80	125
3470 POR 100 P62	3478 POR 100 P62	3477 POR 100 P62	100	125
3470 POR 125 P62	3478 POR 125 P62	3477 POR 125 P62	125	125

Castor Wheels Series AGILA-TWIN

housing made of pressed steel, zinc-chromatised,
wheel made of polyamide, plain bearing

Swivel Type



double ball bearing swivel head,
wheel axle with nut

Brake Type



with wheel brake, double ball bearing
swivel head, wheel axle with nut

Art. No. swivel type	plate fitting / bolt hole	Art. No. brake type	size (mm)	load capacity (kg)
2970 UOO 050 P40		2975 UOO 050 P40	50	70
2970 UOO 050 P30	bolt hole 11 mm	2975 UOO 050 P30	50	70



Castor Wheels



Castor Wheels Series ALPHA

housing made of pressed steel, zinc-chromatised,
wheel centre made of polyamide, white, plain bearing



BETTER MOBILITY. BETTER LIFE.

Plate Fitting

Bolt Hole



Swivel Type

Fixed Type

Brake Type



double ball bearing swivel head,
dustguard, wheel axle with nut

fork made of pressed steel,
zinc-chromatised, wheel axle
with nut

with total lock, tail end of castor,
double ball bearing swivel head,
dustguard, wheel axle with nut

Art. No. swivel type	Art. No. fixed type	Art. No. brake type	size (mm)	load capacity (kg)
3470 UOO 080 P62	3478 UOO 080 P62	3477 UOO 080 P62	80	200
3470 UOO 100 P62	3478 UOO 100 P62	3477 UOO 100 P62	100	200
3470 UOO 125 P62	3478 UOO 125 P62	3477 UOO 125 P62	125	275
3470 UOO 160 P63	3478 UOO 160 P63	3477 UOO 160 P63	160	350
3470 UOO 200 P63	3478 UOO 200 P63	3477 UOO 200 P63	200	350



BETTER MOBILITY. BETTER LIFE.

Castor Wheels



Castor Wheels Series AGILA

housing made of pressed steel, zinc-chromatised,
wheel centre made of Polypropylene
Tread: TENTEprene (thermoplastic rubber),
grey non-marking, plain bearing



BETTER MOBILITY. BETTER LIFE.

Plate Fitting

Bolt Hole



Swivel Type

Fixed Type

Brake Type



double ball bearing swivel head,
wheel axle with nut

fixed castor, fork made of
pressed steel, wheel axle with
nut, plate fitting

with total lock, tail end of castor,
double ball bearing swivel head,
wheel axle with nut

Art. No. swivel type	Art. No. fixed type	Art. No. brake type	size (mm)	load capacity (kg)	plate fitting / bolt hole
2470 PJI 050 P40	2478 PJI 050 P41	2475 PJI 050 P40	50	40	p-fit
2470 PJO 075 P40	2478 PJO 075 P60	2477 PJO 075 P40	75	55	p-fit
2470 PJO 100 P50	2478 PJO 100 P50	2477 PJO 100 P50	100	80	p-fit
2470 PJO 125 P50	2478 PJO 125 P50	2477 PJO 125 P50	125	100	p-fit
2470 PJO 150 P50	2478 PJO 150 P50	2477 PJO 150 P50	150	100	p-fit
2470 PJI 050 P30		2475 PJI 050 P30	50	40	hole 11
2470 PJO 075 P30		2477 PJO 075 P30	75	55	hole 11
2470 PJO 100 P30		2477 PJO 100 P30	100	80	hole 11
2470 PJO 125 P30		2477 PJO 125 P30	125	100	hole 11
2470 PJO 150 P30		2477 PJO 150 P30	150	100	hole 11



BETTER MOBILITY. BETTER LIFE.

Castor Wheels



Castor Wheels Series AGILA

housing made of pressed steel, zinc-chromatised,
wheel centre made of pressed steel
Tread: solid rubber, with threadguards,
grey non-marking, plain bearing



BETTER MOBILITY. BETTER LIFE.

Plate Fitting

Bolt Hole



Swivel Type



double ball bearing swivel head,
wheel axle with nut

Fixed Type



fixed castor, fork made of
pressed steel, wheel axle with
nut, plate fitting

Brake Type



with total lock, tail end of castor,
double ball bearing swivel head,
wheel axle with nut

Art. No. swivel type	Art. No. fixed type	Art. No. brake type	size (mm)	load capacity (kg)	plate fitting / bolt hole
2470 DIK 050 P40	2478 DIK 050 P40	2475 DIK 050 P40	50	40	p-fit
2470 DIK 075 P40	2478 DIK 075 P60	2477 DIK 075 P40	75	55	p-fit
2470 DIK 100 P50	2478 DIK 100 P50	2477 DIK 100 P50	100	80	p-fit
2470 DIK 125 P50	2478 DIK 125 P50	2477 DIK 125 P50	125	100	p-fit
2470 DIK 150 P50	2478 DIK 150 P50	2477 DIK 150 P50	150	100	p-fit
2470 DIK 050 P30		2475 DIK 050 P30	50	40	hole 11
2470 DIK 075 P30		2477 DIK 075 P30	75	55	hole 11
2470 DIK 100 P30		2477 DIK 100 P30	100	80	hole 11
2470 DIK 125 P30		2477 DIK 125 P30	125	100	hole 11
2470 DIK 150 P30		2477 DIK 150 P30	150	100	hole 11



BETTER MOBILITY. BETTER LIFE.

Castor Wheels



Castor Wheels Series LEVINA

housing and wheels made from high grade synthetic materials, with integrated threadguards, all metal parts are yellow passivated, wheel centre made of polypropylene
Tread: TENTEprene (thermoplastic rubber), grey non-marking



BETTER MOBILITY. BETTER LIFE.

Plate Fitting

Bolt Hole



Swivel Type

Brake Type



precision ball bearing, with threadguards

with total lock, tail end of castor, precision ball bearing, with threadguards

Art. No. swivel type	Art. No. brake type	size (mm)	load capacity (kg)
5320 PJP 075 P40	5320 PJP 075 P40	75	100
5370 PJP 100 P50	5377 PJP 100 P50	100	100
5370 PJP 125 P50	5377 PJP 125 P50	125	100
5370 PJP 150 P50	5377 PJP 150 P50	150	100

Castor Wheels for Shopping Trolleys

swivel castor, housing made of pressed steel, zinc-chromatised, double ball bearing swivel head, wheel axle with nut, wheel centre made of polypropylene.
Tread: TENTEprene (thermoplastic rubber), grey non-marking, precision ball bearing, with threadguards, bolt hole



Art. No. swivel Type	size (mm)	load capacity (kg)	plate fitting / bolt hole
2370 PJP 100 P30	100	100	bolt hole 11
2370 PJP 125 P30	125	100	bolt hole 13



BETTER MOBILITY. BETTER LIFE.

Castor Wheels



BETTER MOBILITY. BETTER LIFE.

Castor Wheels grey or blue* Series ALPHA

housing made of pressed steel, zinc-chromatised,
wheel centre made of polypropylene

Tread: elastic-tyre, grey / blue, non-marking, roller bearing

* to order blue version please add „blue“ to the Art. No.

Swivel Type



double ball bearing swivel head,
dustguard, wheel axle with nut

Fixed Type



fork made of pressed steel,
zinc-chromatised, wheel axle
with nut

Brake Type



with total lock, tail end of castor,
double ball bearing swivel head,
dustguard, wheel axle with nut

Art. No. swivel type	Art. No. fixed type	Art. No. brake type	size (mm)	load capacity (kg)
3470 UFR 100 P62*	3478 UFR 100 P62*	3477 UFR 100 P62*	100	160
3470 UFR 125 P62*	3478 UFR 125 P62*	3477 UFR 125 P62*	125	250
3470 UFR 160 P63	3478 UFR 160 P63	3477 UFR 160 P63	160	300
3470 UFR 200 P63	3478 UFR 200 P63	3477 UFR 200 P63	200	400

Walkway Castors - Automatic Wheel brake Series STORA

housing made of pressed steel, zinc-chromatised, double ball bearing swivel head,
wheel axle with nut, wheel centre made of polyurethane.

Tread: polyurethane, 4 tracks, self cleaning between tracks, with threadguards,
precision ball bearing, distances between tracks: approx. 4.5 mm, track

width: approx. 4.0 mm, load capacity 80 / 40 kgs/castor on walkways, bolt hole 12.3 mm



Art. No.	size (mm)
2875 QMP 125 P30	125



BETTER MOBILITY. BETTER LIFE.

Castor Wheels



BETTER MOBILITY. BETTER LIFE.

Medical - Bed Castor Wheels Series SMART

Swivel castor with central, total lock and central directional lock, stem with cam hole for profile bars. Wheel centre made of polyamide
Tread: polyurethane, precision ball bearing



Art. No.	swivel type	size (mm)	load capacity (kg) static
1044 UAP 100 R26-28S45		100	200
1044 UAP 125 R26-28S45		125	200

Medical - Bed Castor Wheels Series SMART

Swivel castor with central total lock, stem with cam hole for profile bars. Wheel centre made of polyamide
Tread: polyurethane, precision ball bearing



Art. No.	swivel type	size (mm)	load capacity (kg) static
1046 UAP 100 R26-28S45		100	200
1046 UAP 125 R26-28S45		125	200

Medical - Bed Castor Wheels Series INTEGRAL

Swivel castor with central, total lock and central directional lock, frame made of pressed steel, precision ball bearing in swivel head and wheel, housing cover made of synthetic plastics, stem with cam hole for profile bars. Wheel centre made of polyamide
Tread: polyurethane, with threadguards, precision ball bearing, sealed



Art. No.	swivel type	size (mm)	load capacity (kg) static
2044 UAX 200 R26-28S45		200	400

Medical - Bed Castor Wheels Series INTEGRAL

Swivel castor with central, total lock, frame made of pressed steel, precision ball bearing in swivel head and wheel, housing cover made of synthetic plastics, stem with cam hole for profile bars. Wheel centre made of polyamide
Tread: polyurethane, with threadguards, precision ball bearing, sealed



Art. No.	swivel type	size (mm)	load capacity (kg) static
2046 UAX 200 R26-28S45		200	400

Castor Wheels



Heavy Duty Castor Wheels Series ZETA

housing made of very heavy pressed steel, reinforced, yellow zinc-plated, wheel centre made of aluminium
Tread: black elastic-tyre, vulcanized, precision ball bearing



BETTER MOBILITY. BETTER LIFE.

Swivel Type



sealed swivel double ball bearing, reinforced and heat treated ball covers, riveted king pin, wheel axle with nut

Fixed Type



fork made of heavy pressed steel, reinforced, yellow zinc plated, wheel axle with nut

Brake Type



with wheel brake, double ball bearing swivel head, wheel axle with nut

Art. No. swivel type	Art. No. fixed type	Art. No. brake type	size (mm)	load capacity (kg)
4680 IEP 125 P63	4688 IEP 125 P63	4687 IEP 125 P63	125	300
4680 IEP 160 P63	4688 IEP 160 P63	4687 IEP 160 P63	160	350
4680 IEP 200 P63	4688 IEP 200 P63	4687 IEP 200 P63	200	400
4680 IEP 250 P63	4688 IEP 250 P63	4687 IEP 250 P63	250	450

Heavy Duty Castor Wheels Series KAPPA

housing made of very heavy pressed steel, reinforced, yellow zinc-plated, wheel centre made of aluminium
Tread: black elastic-tyre, vulcanized, precision ball bearing

Swivel Type



sealed swivel double ball bearing, reinforced and heat treated ball covers, riveted king pin, wheel axle with nut

Fixed Type



fork made of heavy pressed steel, reinforced, yellow zinc plated, wheel axle with nut

Brake Type



with total lock, head end of castor, sealed single swivel double ball bearing, threaded king pin and locking nut secured, wheel axle with nut

Art. No. swivel type	Art. No. fixed type	Art. No. brake type	size (mm)	load capacity (kg)
9680 ITP 100 P63	9680 ITP 100 P63	-	100	400
9680 ITP 125 P63	9688 ITP 125 P63	9682 ITP 125 P63	125	500
9680 ITP 160 P63	9688 ITP 160 P63	9682 ITP 160 P63	160	800
9680 ITP 200 P63	9688 ITP 200 P63	9682 ITP 200 P63	200	800
9680 ITP 250 P63	9688 ITP 250 P63	9682 ITP 250 P63	250	1000



E-DRIVE FLEX - electrical driving unit

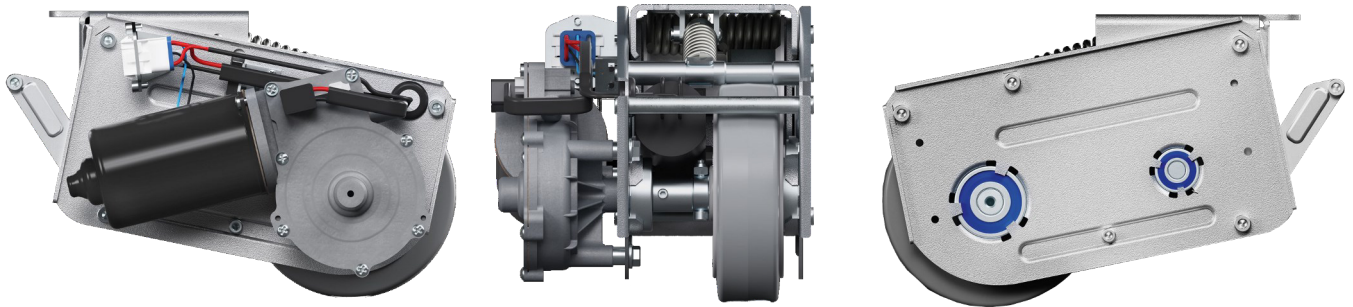

Increased productivity

E-Drive flex helps to make design operational procedures more efficient and, as a result, to realise cost savings.

High flexibility

Thanks to the lifting motor, E-Drive flex can be switched on as required and has no ground contact when in standby position. The practical system also makes it easy to integrate this into existing transport devices.

Improved ergonomics

The ergonomic system helps to prevent ailments to the neck, back, shoulders and hands among users - especially in times of high demographic change. Your investment in E-Drive flex will quickly bear fruit through fewer illness-related absences.



Application example of E-Drive flex

Foldable transport trolley with all E-Drive flex components. The battery displayed here is the lithium-ion battery set.

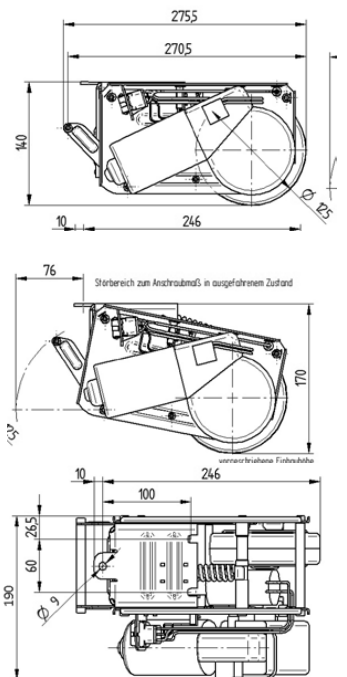

BETTER MOBILITY. BETTER LIFE.